



CBS C100



The C85/100 is a ride-on scrubbing machine characterized by a robust design and "intelligent" soul, capable of revolutionizing the traditional idea of cleaning. Indeed, thanks to the implementation of the most innovative technologies, the user experience has been improved, giving the operator the ability to interact with the machine to make the most of its functions with a view to optimizing operation times and reducing costs.

Innovative technology also means optimal performance and maximum safety. The characteristics and the performance of the C85/100 are

shaped by technology and no longer simply by mechanics: as such, this machine becomes an inexhaustible source of data, connected and therefore capable of exceeding the mere function of simply cleaning floors.

All this without forgetting the comfort of the operator, who, thanks to the driving position inspired by automotive design, can work in a convenient and comfortable position that offers full visibility.

The C85/100 is available in a scrubbing version with 2 disc brushes with 85 cm or 100 cm of working width.



MODELS

C85 B

Scrubbing version with dual brush

Solution tank: 180 l
Working width: 850 mm
Up to 6800 sq.m./h

C100 B

Scrubbing version with dual brush

Solution tank: 240 l
Working width: 1000 mm
Up to 8000 sq.m./h

Performance can be a goal.
Or a starting point...

Extremely versatile, the C85/100 is suitable for working in large spaces in the presence of any type of dirt, even very heavy, and in any type of environment, including production sites, warehouses, shopping centers, supermarkets and logistics centers.

The equipment on this machine and the versions and options available provide operators with maximum flexibility to configure the machine they really need.

A scrubbing machine must be able to adapt to the requirements of the environment in which it works and, above all, of the operator who uses it. **The decision is in your hands!**

The configurations, the options and the accessories available provide an extraordinary opportunity to configure the C85/100 with maximum flexibility, in order to create the perfect machine to respond to the various different cleaning requirements. For this reason, the C85/100

is available in two configurations: Essential and Bright. Indeed, these two configurations provide a choice between machines that outwardly only seem to differ in terms of the presence of the display, but which in reality offer various different possibilities to allow them to adapt to the needs of those who use them.

Essential is indeed a simpler, more essential machine, indispensable for all cleaning operations which are primarily focused on excellent performance.

Bright, meanwhile, is a richer configuration, capable of offering optimal performance combined with the maximum levels of existing technology for scrubbing machines in this category.

... *it's up to you!*

essential



bright

C85

Perfect drying: The C85/100 Bright is equipped with a dual vacuum motor as standard to ensure total drying with no marks in one single pass, thus eliminating the risk of slipping. The equipment of 2 vacuum motors provides the best results even in the most difficult situations.

With the introduction of a new carter attached to the opening of the recovery tank, the vacuum power of the C85/100 is further improved, ensuring that there are no leaks between the cover and the tank itself.

Excellent autonomy is also a feature of the C85/100, which thanks to the capacity of its tanks, can work for up to 4 hours non-stop.



LED rear headlights as standard

The C85/100 is equipped with a hydraulic brake which acts on the rear wheels for the work brake, thus increasing safety and comfort.

Brushless motors to reduce maintenance and costs of ownership.

The brush head is equipped with 2 disc brushes, offering superb cleaning performance in all dirt situations.



C85/100



LED front headlights as standard



Front motorwheel in AC with antiskid and anti-mark wheel to ensure maximum adherence on any type of floor, even when wet. The motorwheel in the front position enables optimal manoeuvrability even in congested spaces, and furthermore, gives the machine a greatly reduced turning circle. This makes the C85/100 range suitable for working in any environment.



The electric brake installed on the front motorwheel functions as parking brake.

Ramps at 18% with empty tanks



Pressure Monitoring is the system for constant monitoring of the power dispensed by the motors on the brushes and guarantees maximum effectiveness on any type of flooring. The maximum pressure exerted on the brushes of the C85/100 is 150 Kg.



Moving scrubbing brush head: on activating a simple control, the moving brush head comes out to the right to reach the dirt that settles up against walls. This solution enables the machine to scrub and not just sweep as occurs with scrubbing machines equipped with side brushes.





The bumpers are made from R.I.M. polyurethane, a material that is also used for automotive components as it is highly resistant to impacts. The design of the bumpers allows the mechanical parts of the C85/100 to stay protected inside the machine body.

The structure, the robust materials from which it is made and the functional design make it a machine that is reliable over time. The steel frame is coated with cataphoretic paint which provides it with remarkable resistance to corrosion.

The brush head of the C85/100 is made from steel. This provides lasting robustness and reliability.

The new drive system with high efficiency gearmotors significantly increases the performance of the brush head, minimizing energy consumption. The brushless-type motors, meanwhile, are completely hermetic and do not require maintenance, thus reducing costs of ownership.

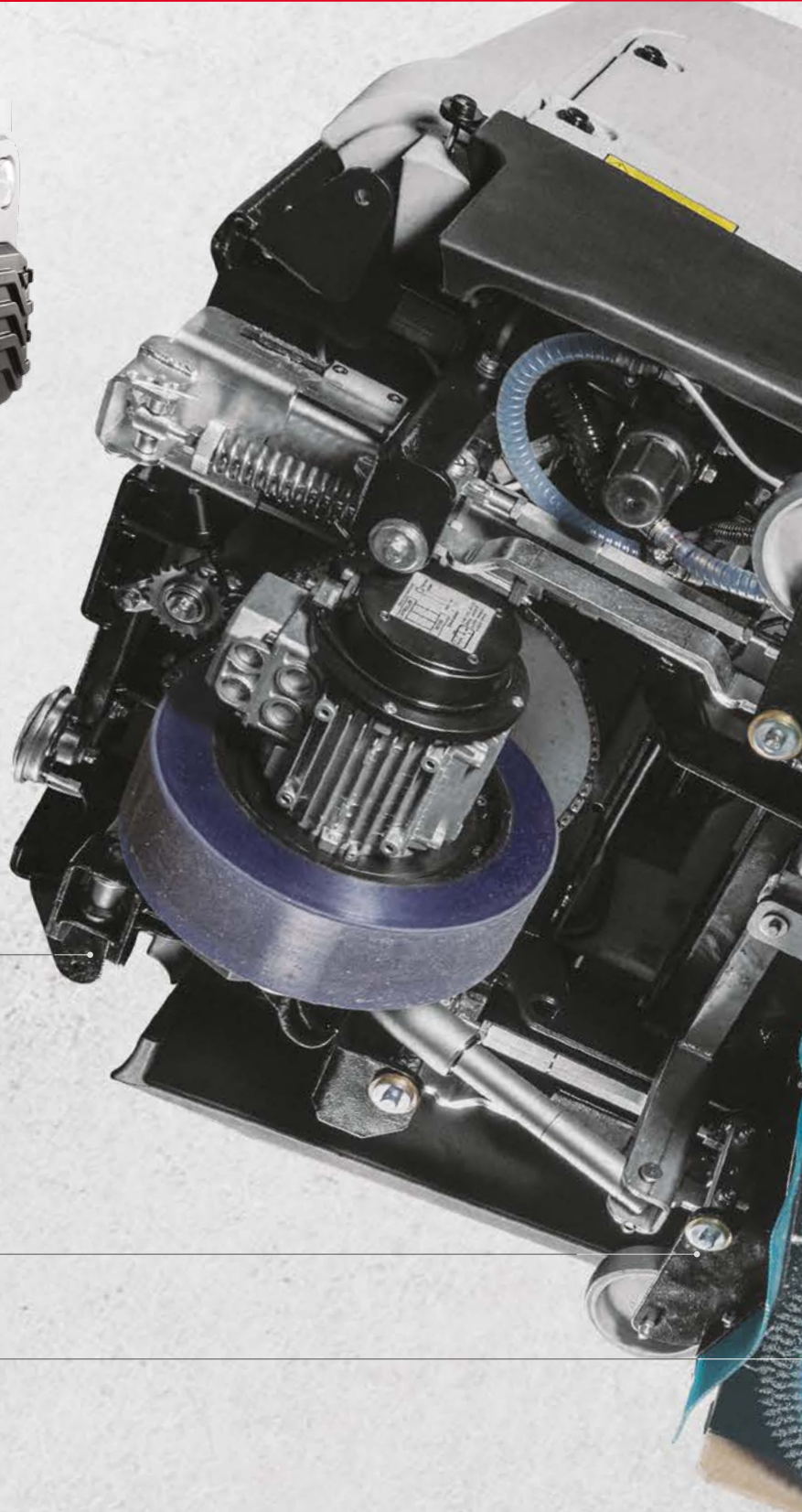

reliable scrubbing machine

The self-levelling lateral splash guards keep water inside, while the V-shape of the squeegee allows it to be directed to the center to facilitate vacuum, achieving a uniform clean.

The splash guards, squeegee and squeegee support are made from aluminum to render them robust and easy to treat against corrosion.

Furthermore, the squeegee support of the C85/100 is equipped with castor wheels to allow it to efficiently follow all of the movements of the scrubbing machines.





Emergency Stop. In an emergency, simply press a single button to immediately halt forward movement and all other functions of the C85/100. The blinking light helps make the machine visible while working, while the buzzer provides an acoustic warning that the machine is moving in reverse.

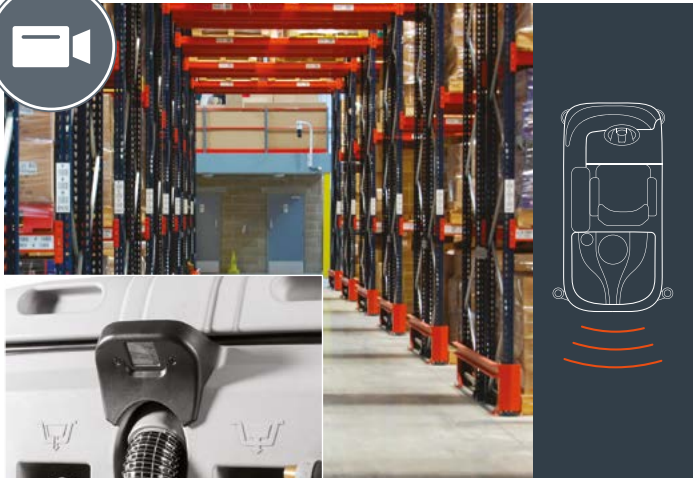

The rear view camera on the C85/100 Bright supports the operator, allowing him to check for any obstacles in maximum safety when moving in reverse.



LED lights



Standard lights



Front and rear LED headlights are provided as standard, because it is important to provide maximum visibility for the operator, but also because it is essential to make the machine visible. The LED headlights ensure maximum safety when working by illuminating areas that are shaded and signaling the presence of the moving machine. The energy savings achieved thanks to the use of LED technology are significant, with up to 80% less energy used than with standard headlights. Furthermore, the LED headlights provide even clearer and more uniform illumination of the track ahead.



Rapid cleaning operations to optimize time: up to 8 km/h when working. A continuous sensor positioned on the steering wheel axle recognizes the exact position of the front motorwheel, automatically reducing the speed of the machine in accordance with requirements. The sensor allows the C85/100 to move forward in a fluid manner, without interruption.

A detailed ergonomic study has enabled optimal adaptation of the man-machine system, to provide the operator with a comfortable and well-protected seat. The working position is raised and decentralized to improve visibility during cleaning operations.



To protect the C85/100 from being tampered with, it is possible to set a personalized password for the operators who use the machine, in order to allow customized access to the functions according to the user.



Stop & Go. When the machine is temporarily idle, the solution flow is interrupted, the brushes are halted and the brush head is automatically lifted off the floor, with no need for operator intervention so that consumptions are optimized and wastes reduced. Pressing the forward movement pedal restores the functions that were previously activated.



Side bumper rollers protect the machine and the surrounding environment during delicate manoeuvres, for example when cleaning along walls and shelving.



To further increase safety, anti-collision sensor can be installed on the rear part of the machine. The detection of the presence of any obstacles is an excellent means of support for the prevention of accidents when using the C85/100.

The technology developed for the C85/100 improves the user experience



In the Bright configuration, after selecting the type of work, the desired cleaning program can be selected via the touch screen display: Eco, Standard and Plus. The operator interacts with the scrubbing machine via the selector and the touch screen display, thus enabling him to remain in a comfortable position whilst activating the necessary functions. This interaction with the display allows the operator to quickly and easily change the parameters of the cleaning programs in order to use specific quantities of water, detergent and pressure for working in different dirt conditions.

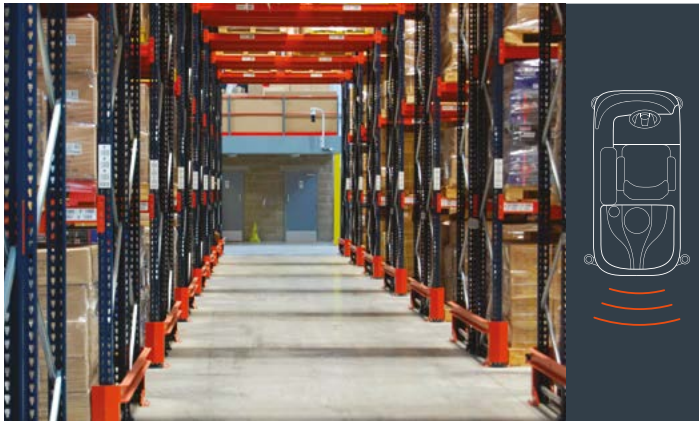

The display of the C85/100 Bright is connected to the rear view camera and enables the machine to be used in an even easier and safer way.



Operator training plays an essential role in ensuring optimal use of the scrubbing machine and above all in safeguarding the health and safety of people. The video tutorials help to simplify the use of the machine and correctly perform routine and extraordinary maintenance on the C85/100. Furthermore, the touch screen display of the Bright configurations enables the tutorials to be viewed at any time, thus allowing the scrubbing machine to be used correctly even by different operators to those who normally use it.



Using the C85/100 is extremely easy thanks to the working program selector which enables the selection of the type of activity to be carried out: scrubbing and drying, scrubbing and drying with the moving brush head, scrubbing only, or drying only.



and gives the operator the ability to interact with the machine

All the intelligence of the C85/100 Bright is in your hands thanks to the touch screen display with a 7" color screen which makes it even easier and more intuitive for the operator to use the machine. This super-advanced scrubbing machine is thus rendered simple and easy to use, as the operator can communicate directly with the machine. How? By translating all of the complex data collected into information that is accessible to people. This provides the operator with all of the tools necessary to control the cleaning operations. Furthermore, Comac has designed the C85/100 software to provide those using it with the same familiarity and ease of use as a smart phone or a tablet.



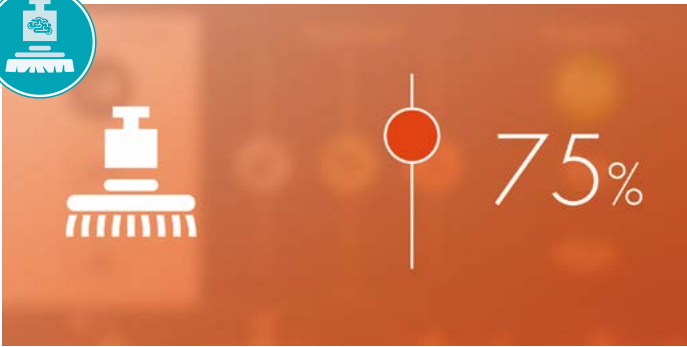

INTELLIGENT PRESSURE MONITORING

The C85/100 Bright can be equipped with IPM (Intelligent Pressure Monitoring). This is not a simple pressure sensor, but rather a weight sensor which can provide the operator with a constant and accurate measurement of the pressure exerted on the brushes. IPM provides further support to the operator when facing situations that require heavy duty cleaning. Furthermore, the pressure indication is extremely reliable as it displays the actual kg exerted on the brush head.

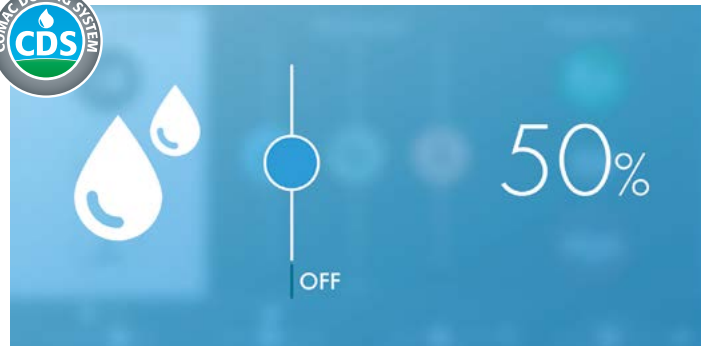

CDS - COMAC DOSING SYSTEM

The C85/100 can be equipped with CDS, the dosing system created by Comac with two separate circuits which allow the operator to measure out the water and the detergent separately. This means that the amount of solution can be immediately adapted to the specific dirt to be cleaned, thus eliminating the excesses that can occur with traditional scrubbing machines. The Comac Dosing System reduces cleaning solution consumption by up to 50%.



SOLUTION LEVEL SENSOR

In the Bright configuration, the C85/100 is equipped with the solution level sensor, which allows the operator to remain up to date with regard to the level of solution present in the tank without having to check it personally.



CONSTANT SOLUTION FLOW

To ensure correct distribution on both of the brushes, the C85/100 is equipped with a solution pump as standard, to guarantee homogeneous and uniform delivery over the entire working width. Indeed, the Constant Solution Flow improves cleaning efficiency even with low flow rates and allows the use of detergent solution to be optimized.



SPRAY TOOL

The Spray Tool with which the C85/100 can be equipped enables even easier and more efficient cleaning of the tanks. Furthermore, it is possible to spray the solution even on surfaces that cannot be reached by the machine.



SUCTION TOOL

Thanks to the vacuum wand, it is possible to clean even the most hard to reach areas with the machine, thus maximizing the productivity of the C85/100.

machines designed to place the operator at the center



Comac Fleet Care: manage your fleet, increase your efficiency!

Comac Fleet Care is the new service that enables all those who manage a fleet of machines deployed on different sites to monitor everything that happens to the machines, as if they were there in person.

CFC collects the data sent by the machines and converts this into information that is used to improve coordination, optimize performance and increase fleet efficiency, while maintaining benefits over time.

This service provides a complete and up-to-date overview of the status of each machine, which can be viewed online, any time, on any device - tablet, smartphone or computer. Fleet managers can check that their machines are being used properly in the places and times specified, and where an issue occurs, they are immediately notified so that the situation can be promptly rectified.

The CFC system helps to optimize machine use, increasing productivity by avoiding wasted time and preventing unforeseen events from occurring whenever possible.

The privilege of working in complete comfort



The steering is light, to provide the operator with an even more comfortable driving experience. The steering wheel itself, with an automotive-derived design, has been specially conceived by Comac to guarantee the highest levels of comfort and user experience.



Near the steering wheel, in an easy to reach position for the operator, is the forward movement/reverse lever, which also provides a choice of 3 preset working speeds.



The C85/100 can be equipped with a LED courtesy lights pack to increase the visibility of the parts where the operator may be required to perform maintenance.

The anti-collision sensor with which the C85/100 can be equipped allow any obstacles to be detected while the operator is comfortably in the driving position.



The driving position has been revolutionized. The new generation steering wheel and drive pedal and the seat with super comfortable armrests ensure maximum comfort for the operator even when the C85/100 is used for long periods. The lowered footboard allows the operator to get on and off the C85/100 with ease, so that all activities can be performed optimally.

Thanks to the rear view camera, operators using the C85/100 Bright can check the cleaning performance whilst remaining comfortably in position, without having to look in the opposite direction to the direction of travel.



Comac technologies at the service of the environment



Comac has always been committed to creating its products by respecting the environment, investing in the development of sustainable solutions and technologies, seeking materials that can easily be recycled, and ensuring that the entire production process has a low environmental impact. As part of a circular economy logic, C85/100 machines have been designed right from the start with their end of life cycle destination in mind, thus focusing on recovery rather than disposal.

THE PROGRAMS AND TECHNOLOGIES ARE DESIGNED TO REDUCE CONSUMPTION, LOWERING CLEANING COSTS THANKS TO THE OPTIMIZATION OF OPERATION TIMES.



The C85/100 uses technologies that help save resources. The cleaning operations performed in ECO Mode enable a reduction in the amount of water, detergent and pressure delivered. This work mode prevents water, detergent and energy consumption, by using only the quantities necessary. Furthermore, the ECO Mode function allows the noise level produced by the C85/100 to be reduced, making this scrubbing machine suitable for performing silent operations, saving energy and increasing autonomy.



ECO Mode activated

The C85/100: an answer to your needs

The range of configurations, equipment, options and accessories on offer is very wide and the versatility of the C85/100 scrubbing machines means that it is possible to use them in very different environments, including production departments in the industrial sector, warehouses, shopping centers, supermarkets or logistics centers.



Logistics



Large-scale retailing



Automotive



Cleaning contractors



Industry



Transport

Correct daily maintenance keeps scrubbing performance constant



The C85/100 cleans easily but is also easy to clean. Indeed, the wide opening on the tanks enables better cleaning and sanitizing of the interiors, reducing dirt sedimentation and the unpleasant smell that can be generated inside. Furthermore, the spray gun facilitates rinsing of the recovery tank at the end of cleaning operations. To achieve ever better cleaning results, it is essential to ensure the maximum level of vacuum performance. With this in mind, Comac has equipped the C85/100 with a basket filter which stops any detritus and prevents it from being deposited at the bottom of the recovery tank, making cleaning easier. Furthermore, the anti-foam filter with which the C85/100 is equipped protects the vacuum motors against foams from detergents.



Comac has always been focused on simplicity of maintenance for its scrubbing machines. The C85/100 has been designed to assist the operator in these phases, and can be equipped with the Fast Filling System which enables the quick filling of the clean water tank without the presence of the operator.



The C85/100 is equipped with squeegee rubber blades and 40 shore splash guards as standard, which have a greater useful life and offer better performance on floors with leaks. Both can be used on all 4 sides, and in order to further simplify maintenance operations, the new locking system in stainless steel enables the blades of the squeegee and the splash guards to be replaced without using tools.



The parts which require daily maintenances are yellow in color, to make them easy to identify.



The system for uncoupling the brushes via a knob positioned on the brush head makes this operation significantly easier.

STANDARD EQUIPMENTS	Essential	Bright	Bright full optional
Comfort			
Hour meter	•	•	•
Display touchscreen 7"	-	•	•
Videotutorial on-board	-	•	•
Knob for brush uncoupling	•	•	•
Eco Mode and Plus Mode	-	•	•
Speed adjustment (3 pre-set positions)	•	•	•
40 shore splashguards usable on 4 sides	•	•	•
Color-coded parts for easy maintenance	•	•	•
Water indicator light	•	•	•
Super comfortbale seat with armrest	•	•	•
Decentralized driving position	•	•	•
Safety			
Emergency stop	•	•	•
Automatic parking brake and assisted uphill departure	•	•	•
Hydraulic working brake	•	•	•
Bumpers made from R.I.M. polyurethane	•	•	•
Antiskid wheels	•	•	•
Dead man's switch	•	•	•
Speed and stability control system	•	•	•
Reverse warning device	•	•	•
Horn	•	•	•
LED front headlights with two different light levels	•	•	•
LED rear headlights and stop light	•	•	•
Stop&Go	•	•	•

OPTIONAL	Essential	Bright	Bright full optional
CDS (Comac Dosing System)	• With button	• Touch screen	• Touch screen
CFC (Comac Fleet Care)	•	•	•
ST (Spray tools)	• With button	• Touch screen	• Touch screen Standard
ST (Suction tools)	• With button	• Touch screen	• Touch screen Standard
IPM (Intelligent pressure monitoring)	-	•	• Standard
Brush head with right-hand movement	• With button	• Touch screen Standard	• Touch screen Standard
Rear camera	-	•	• Standard
Anticollision sensor	•	•	• Standard
Suction dual power Extreme	•	• Standard	• Standard
Solution level sensor	-	• Standard	• Standard
Courtesy lights pack	•	•	• Standard

ACCESSORIES	Essential	Bright	Bright full optional
Fast filling system	•	•	• Standard
Seat belts	•	•	• Standard
Shorter squeegee (900/35,4 mm/inch C85 - 1105/43,5 mm/inch C100)	•	•	•
Rain protection	•	•	•
Overhead guard	•	•	•

TECHNICAL DESCRIPTION		C85	C100
Solution tank	l/gal	180/47,5	230/60,75
Recovery tank	l/gal	180/47,5	240/63,4
Detergent tank capacity (CDS)	l/gal	12/3,17	12/3,17
Working width	mm/inch	850/33,4	1000/39,3
Squeegee width	mm/inch	1105/43,5	1305/51,37
Moving scrubbing brush head	mm/inch	150/5,9	150/5,9
Working capacity up to	sq.m/h/sqft/h	6800/73194.59	8000/86111.28
Autonomy	h	4	4
Acoustic level (ISO 11201)	db (A)	<70	<70
Disc brush	(n.) mm/inch	(2) 430/17	(2) 510/20
Brush pressure	Kg/lbs	150/330,7	150/330,7
Brush motor	V/W	(2) 36/750 AC	(2) 36/750 AC
Brush revolution	rpm	180	180
Vacuum motor	V/W	(1-2) 36/650	(1-2) 36/650
Suction vacuum	mbar	190	190
Traction	-	front aut. electrobrake	front aut. electrobrake
Traction motor	V/W	36/1200 AC	36/1200 AC
Forward speed	Km/h/mpH	0+8/5	0+8/5
Max gradient at full load	%	10	10
Max gradient with empty tanks	%	18	18
Batteries (qty)	V/Ah C5	Box-36/360	Box-36/360
Batteries weight	Kg/lbs	420/926	420/926
Machine weight (without batteries)	Kg/lbs	490/1080,27	516/1137,59
Machine dimensions (Lxhxw)	mm/inch	1917x1630x961/ 75,5x64,2x37,8	1917x1730x1095/ 75,5x68,1x43,1





COMAC S.p.A. Via Maestri del Lavoro, 13 - 37059 Santa Maria di Zevio - Verona - ITALY
Tel. 045 8774222 - Fax 045 8750303 - www.comac.it - com@comac.it
Organisation certified by Q.C.B. Italia ISO 9001:2015, ISO 14001:2015, OHSAS 18001:2007

